



INTELLIGENT CUTTING & FINISHING

Jingwei Systemtechnik is a global leader in plotter and digital cutting technology. As technology pioneers, we are committed to driving a revolution through relentless innovation and continuous product enhancement. Our ever-evolving portfolio is designed to meet the dynamic needs of various industries, making Jingwei a trusted name in the footwear, apparel, packaging, signage, electronics, and leather industries.

Our innovation. Your success.

SIGNAGE GRAPHICS

SG 1625

New generation cutting & finishing solution



JINGWEI

SYSTEMTECHNIK

With a 30-year legacy of innovation and excellence, JWEI has been at the forefront of cutting technology, shaping the industry with advanced, automated, and highly adaptable solutions. As the leading force in flexible material cutting in the domestic market, we have expanded globally, earning a reputation for precision, efficiency, and high performance.

For over a decade, we have been a trusted partner in the signage and surface graphics industries, delivering digital finishing and cutting systems that seamlessly handle an extensive range of rigid and flexible materials.

Our solutions are engineered to meet the evolving demands of modern production, ensuring unmatched accuracy and reliability.

With a strong emphasis on customization and intelligent automation, JWEI empowers businesses to optimize production, streamline workflows, and maximize efficiency. Built for speed, accuracy, and adaptability, our cutting-edge technology is transforming industries worldwide.

30th

30 years of technological excellence

120⁺

Active in over 120 countries & regions

300⁺

More than 300 sales and service networks

30000⁺

Chosen by over 300,000 global customers

8⁺

Servicing the needs of multiple industry sectors

200⁺

More than 200 patents



SG1625

New generation cutting & finishing solution

Our innovation. Your success.

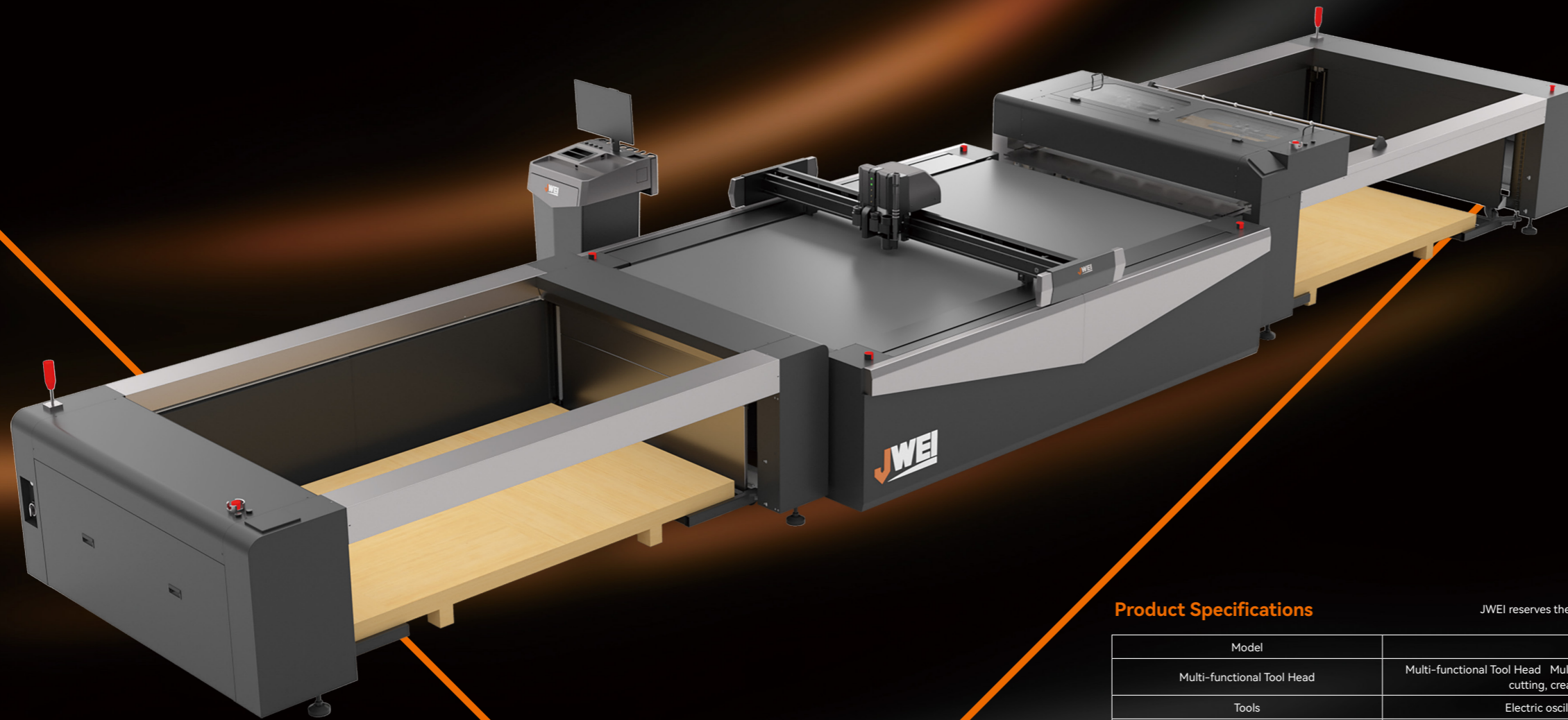

Product Specifications

JWEI reserves the right of final interpretation of the following parameters, subject to change without prior notice.

Model	SG1625
Multi-functional Tool Head	Multi-functional Tool Head Multi-tool fixing holes, quick insert tool fixing, easy-to-replace cutting tools, plug-and-play, set cutting, creasing, drawing, router and other functions in one, optional ATC module.
Tools	Electric oscillating tool, drag knife, rotary tool, router tool module, plotting tools, etc.
Fastest speed	2000mm/s *
Max. Cutting Thickness	50mm *
Maximum loading height (including pallets' height)	750mm
Maximum feeding thickness	22mm
Single sheet feeding weight	5kg
Maximum loading-unloading material size (WxL)	1600mm×2500mm
Minimum loading-unloading material size (WxL)	600mm×900mm
Cutting Materials	ABS board, PVC board, space board, aluminium-plastic board, lamp sheet, back glue, PVC foam board, KT board, acrylic, magnetic sticker, self-adhesive, etc
Material Fixation Mode	Vacuum absorption
Transmission Mode	Ethernet port
Drive System	Bus controller, advanced servo system, imported linear guide rail, lead screws, grinding level 0 backlash helical teeth
Rated Power	21kW
Rated Voltage	380V±10%
Effective Cutting Size (WxL)	1600mm×2500mm
Machine Size (WxLxH)	2620mm×10660mm×1410mm (feeding: 2060mm×3630mm×1250mm, cutting: 2560mm×3380mm×1410mm, receiving: 2060mm×3630mm×1250mm)



Fast & precise



MES system



Automatic Tool Changer

Note: * Dependent on materials and application



Reimagined Design

Advanced industrial design

Featuring a polygonal fold structure for a sleek contemporary aesthetic

Enhanced ergonomics

A superior user experience enhanced by stability and durability



Optimized functionality

Smart control software

Simplified operation in a single step

Modular design, flexible splicing

Versatile operating platform

A variety of tools and blades for an efficient workflow

Noise reduction technology

Now 64db for lower sound and lower frequency



Performance that delivers

Improved speeds

Now 33.3% faster than the previous generation

New proprietary chip for precision motion

Ultra precise 0.00015s motion control for redefined speed, accuracy, and efficiency

One touch start

Effortless set-up for instant activation



Maximized Intelligence

MES System

Streamlining production for smooth operation

Automatic tool changer*

Hands free, completing complex changes with one click



Increased accuracy

Enhanced precision

Delivered by a fully proprietary control system

Advanced stability

Powered by a modular integrated machine structure

Grinding grade drive system

Engineered with a high-precision gantry control algorithm

Stronger vacuum hold

Over three times the suction power to ensure complete material stability on the bed

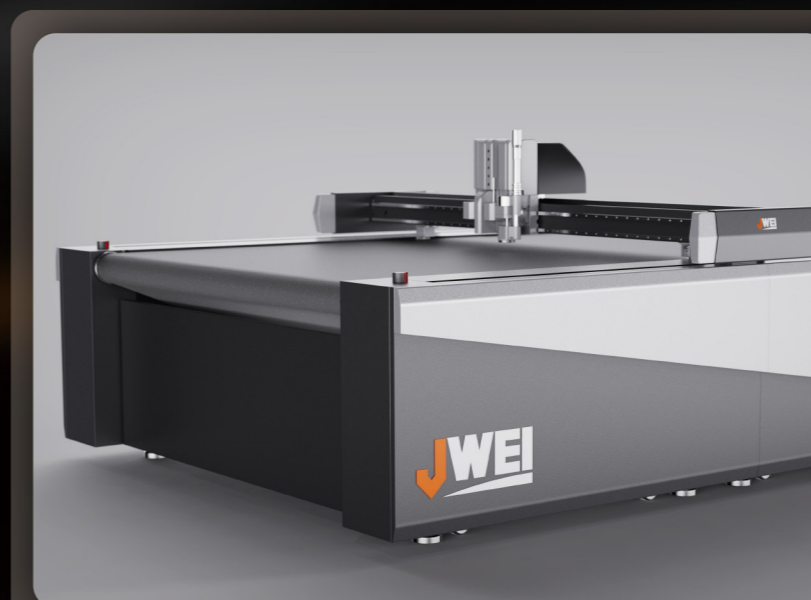

Additional highlights

NFC Access Control

Wireless charging

Automatic tool setting

Scene software

Automatic router tool change*



Our innovation. Your success.

NINGBO JINGWEI SYSTEMTECHNIK LTD.

Address: No. 1206, Jianlan Road, Yinzhou District, 315040, Ningbo, China

Hotline: +86 574 87913531 87900713 | Email: info@jingwei.com.cn | www.jweicut.com