

# HandTop

## HT1600UV HK Kyocera Hybrid Inkjet Printer

### Operation Manual



## Safety Precautions

### 1. Indications of symbols

Note the specific features given with these symbols in order to avoid property damage and personal injury in the operating process.



This symbol indicates the failures to be caused by the ignorance of misunderstanding of the instruction may probably lead to equipment damage or personal injury.



This symbol indicates the compulsory operations.



This symbol indicates the improper operation to be strictly prohibited

## 2. Precautions of operations



### Caution

Please supply the printer with rated voltage and frequency, improper power input may cause functional abnormality or damage to the printer.

Any unauthorized alteration is strictly prohibited, or it might cause parts malfunction or damage to the printer.

Never use the printer in a non-ventilated or stuffy workplace, or it may lead to toxic hazards to operators. A ventilator is always a necessity.

Any disassembly or replacement of the parts and cables is strictly prohibited in the state of power-on.

Avoid any body contact with the locomotion parts in the process of printer working, or it may lead to equipment breakdown or personal injury.

The printer is a precision equipment and should always avoid strong impact or shake in any process of loading, installation and operation, or it may result in equipment damage.

Avoid any liquid spilled on the electronic parts or it may result in parts malfunctions.

Keep the chemical consumables away from non-qualified individuals and stored according to the specific instructions.

Avoid setting foot or heavy items placed on the printer or it may result in equipment damage.

Verify that the printer is properly ground wired or it might cause some electric shock risks.

The operator must be well-properly trained and should operate the machine under the instructions, or it may easily cause equipment damage or personal injury.

Always remember to press the scram stop at any emergency, and the printer should not be activated until all the malfunctions are settled.

Avoid continuous eye-contact with the ultra-violets of the lamp.

Wear rubber gloves to avoid chemical liquid spilled on human body. Flush with adequate purified water immediately if accident happened and see a doctor afterwards.

Verify that there is no individual or item within the printing area.

The treatment of the waste chemicals should abide by local environment regulations.

## Brief introduction

### 1. Printer Applications

The UV digital printer is able to print directly on diversified media. The model can be used in advertising production such as banner, panel led, POP stand, vinyl display, meanwhile make creative innovation to the traditional craftwork in the decoration industry, of which fine-art glass, wooden products, natural or artificial leather, ceramic tiles and wallpaper, etc, can also be printed on.

### 2. Printer Features

- With the self-R&D ability that enables constant advancement.
- Professional assembly crafts guarantee the perfect qualities.
- Adopt excellent quality parts of worldwide famous brands, e.g. towline of EGUS.GERMANY, servo motor of FUJI.JAPAN, synchronous belt of MEGARDYNE.
- Iron beam plus dual lead rails assembly on X-directional mechanical structure enables the carriage to run stably.
- High precision linear encoder strip for the positioning of the carriage.
- Optical fiber with a maximum transmitting speed of 1.25 Gbit/s and zero-interference ability.
- Industrial PCI data transmitting interface with excellent proof to electric-magnetic interference.
- Automatic head height adjustment enables the head height adjustable to different media thickness of 0-50mm.
- Dual lead screws on the Y-directional mechanical structure guarantees the basis of the stable and high precision stepping movement.
- Anti-crashing attachment can effectively reduce the head-strike risks.
- Self-checking on printer running malfunctions.
- Double-class ink-heating automatic control guarantees the optimum viscosity of ink for printhead continuously discharging.
- Backup storage battery activated automatically for negative pressure system in the state of main power-off.
- More intuitive and user-friendly operating interface.
- With the ability to 24 hours X 7 days continuous running of commercial printing production.

## 4. Structure Diagrams

### 4.1 Front-view of the printer

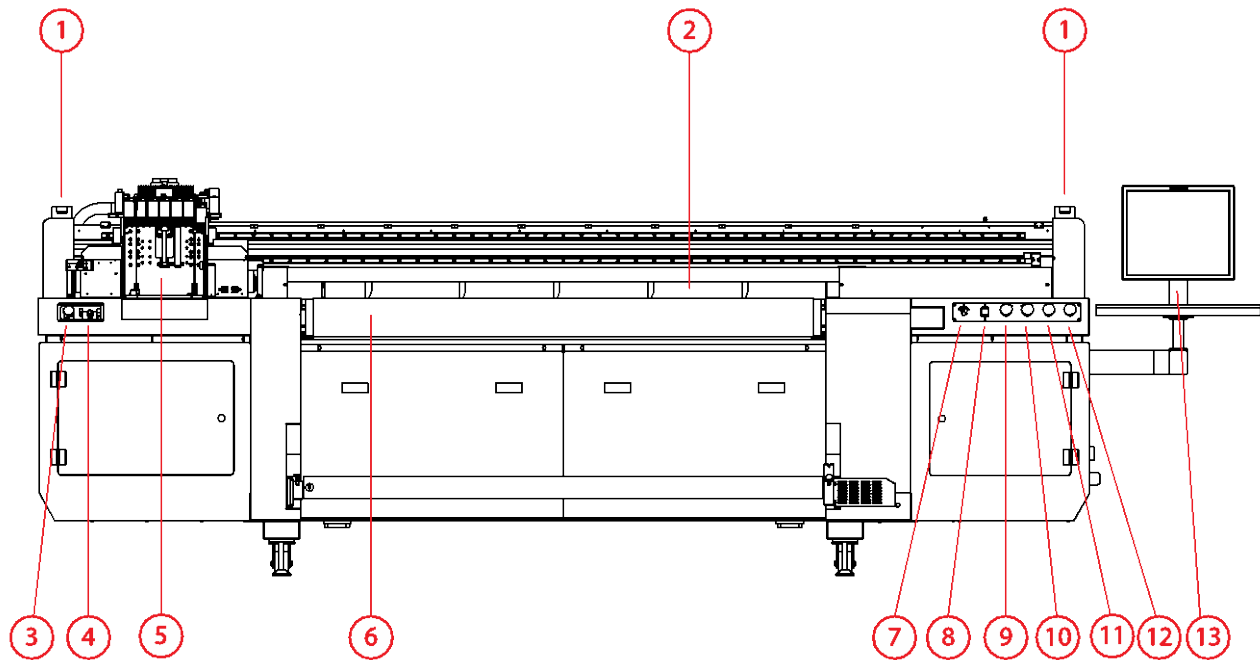

#### Parts Illustrated:

- ① Emergency Stop Button
- ② Media Alignment Bar
- ③ Ink Prime Button
- ④ Negative Pressure Adjust Knob
- ⑤ Carriage Assembly
- ⑥ Conveyor Belt
- ⑦ Media Feed Tension Adjustment
- ⑧ Media Tension Direction Button
- ⑨ Power/Start Button
- ⑩ UV Lamp Power Button – Lower Power
- 11 UV Lamp Power Button – High Power
- 12 Printing Platform Suction Power Button
- 13 Computer Screen

## 4.2 The front-view of the carriage

Parts Illustrated:

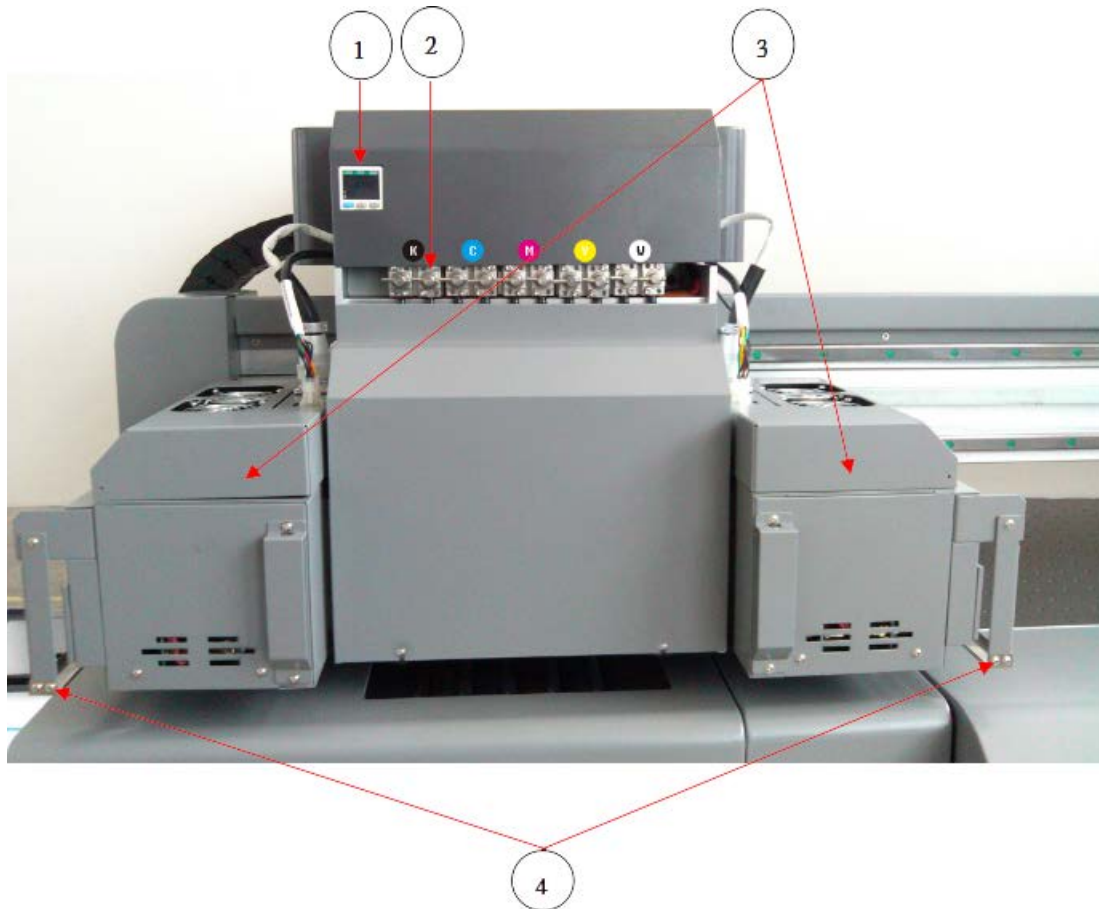

Valve of the subtank

- ① power indicating led
- ② valve of the subtank
- ③ UV lamp assembly
- ④ anti-crashing attachment

- Use the lever type grease gun to eject the lubricating grease into the slide block via the lubricating nipple assembly on the block.
- Non-clean lithium grease must avoid to be used for lubrication job or it will result in slide way and slide block damage.
- The moving parts need to be under good maintenance includes X-directional slide way, Y-directional slide way, Y-directional screw leads, Z-directional screw lead.

### **3. Precision part maintenance**

- All precision parts must be strictly cleaned with isopropanol and lint-free tissue according to the maintenance instructions.
- The precision parts needs to be under good maintenance includes encoder strip, opt-electric sensor, head height finder assembly.

### **4. Printhead maintenance**

#### **4.1 Daily routine maintenance**

- Every day before or after work, take a nozzle checking print and see if there is any blockage. Execute priming or flushing immediately as soon as any blockage is observed.
- Tidy and clean the printing platform and the bottom of the printhead tray.
- On the occasion of only one or two color discharging during the printing process, a synchronic color bar printed with the image is strongly recommended, so that all the other colors can also discharge in the whole process. Thus avoid constant reflective UV light causes the non-discharging nozzles clog.
- Execute anti-dust and anti-electrostatic operation if necessary.
- Double-check the smoothness of the media when placed on the platform so as to avoid head strike incidents.

#### **4.2 Printhead preservation during power failure**

- If ever encountered with a power failure, and you have no idea of when there will be supply again, the printhead preservation needs to be done. Follow the instructions below.
- Preservation instructions
- Get a KT board the size of the printhead tray and wrap it with preservation film.
- Carefully lay some lint-free tissue on the surface and use some flushing to moisture it.

- Put the moisturized KT board under the printhead tray, then roll the Z-directional screw lead manually, making the carriage lowering down till the two surface adhere to each other. (slightly contact is right, avoid pressing too hard)
- Turn off the valves and disconnect the cable terminal of the air pump.
- Turn off the main circuit breaker.

## 4.3 Printhead preservation during long vacation

- When the printer stays non-working over 3-day or even longer vacation, the printhead will need to be cleaned and flushed. Follow the instructions below.
- Press the scram stop and shutdown the computer, turn off all the circuit breakers.
- Turn off all the valves of the subtank and disconnect all the terminals of the air pump.
- Unscrew the joint of the disk filter and use a syringe to get rid of all the ink within the printhead. Avoid excessive pressure onto the printhead or it would cause damage to the internal components. Slightly doing this till you see constant ink droplets come out of the nozzles.
- Use a clean syringe to flush the head with specific flushing till you see the liquid comes out of the nozzle becomes transparent.
- Keep some flushing remained in the printhead and preserve the heads as the instruction described above.

## 5. Replacement of consumable parts

### 5.1 The replacement of UV lamp

- Replace when the lamp is broken or can not light regularly.
- Replacement instructions
- Step one. Turn off the UV lamp activating button and UV power circuit breaker.
- Step two. Disconnect the plug of the UV power cable and the fans cables. Illustrated as below.



Printer maintenance schedule

Order	Maintenance Items	Tools and Materials	Period																												
				Mon.	Tues.	Wed.	Thur.	Fri.	Sat.	Sun.	Mon.	Tues.	Wed.	Thur.	Fri.	Sat.	Sun.	Mon.	Tues.	Wed.	Thur.	Fri.	Sat.	Sun.							
1	Cleaning printer appearance	1.3.4.6.7.1 0.12	daily	◆	◆	◆	◆	◆	◆	◆	◆	◆	◆	◆	◆	◆	◆	◆	◆	◆	◆	◆									
2	Check if there is ink in the air tube	3.4	daily	◆	◆	◆	◆	◆	◆	◆	◆	◆	◆	◆	◆	◆	◆	◆	◆	◆	◆	◆									
3	Clean the platform and the sucking holes	1.4.6.13	daily	◆	◆	◆	◆	◆	◆	◆	◆	◆	◆	◆	◆	◆	◆	◆	◆	◆	◆	◆									
4	Check the nozzle state	1.3.4.6.7.1 0.12	daily	◆	◆	◆	◆	◆	◆	◆	◆	◆	◆	◆	◆	◆	◆	◆	◆	◆	◆	◆									
5	Clean the quartz glass and the printhead tray	1.2.6	daily	◆	◆	◆	◆	◆	◆	◆	◆	◆	◆	◆	◆	◆	◆	◆	◆	◆	◆	◆									
6	Cleaning the towline and check if there is any leakage of tubes	2.3.6.11	daily	◆	◆	◆	◆	◆	◆	◆	◆	◆	◆	◆	◆	◆	◆	◆	◆	◆	◆	◆									
7	Execute calibration and alignment	15	weekly	◆						◆																					
8	Clean the waste ink collection	1.2.5.6.11	weekly	◆						◆																					
9	Replace the filtration fiber	1.3.4.6.7.1 0.12	weekly	◆						◆																					
10	Clean the fans and internal device	--	weekly	◆						◆																					
11	Lubricate the rolling or moving parts	15	weekly	◆						◆																					
12	Check and see the joints of tubes	4.8.9.11	monthly	◆																											
13	Replace the shutter of UV lamp assembly	--	monthly	◆																											
14	Replace the pump and filter	14.5	half-year																												
15	Replace the optical fiber	14	half-year																												
16	Reset the pressure indicator	4.6.13	yearly																												
17	Replace the quartz glass of UV lamp	2.3.5.6.11	yearly																												

Please contact with HANDTOP for more technical report when necessary.